

**120 LB. DRUM SIZE      50:1 RATIO**

**\*REFER TO SEPARATE INSTRUCTIONS**  
815 Coupler — Section G9, Page 2 Series.  
82050 Basic Pump — Section A5, Page 7 Series.

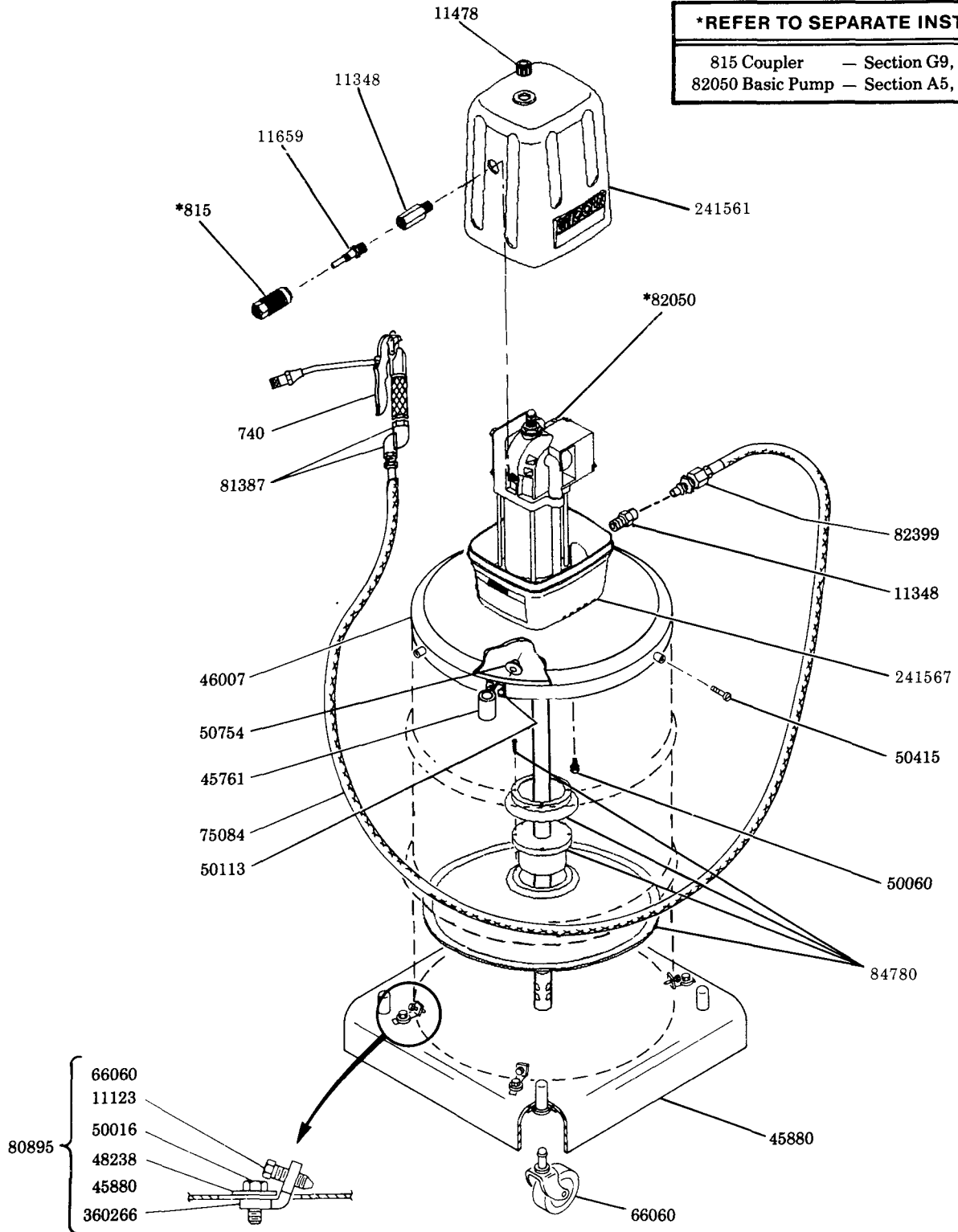

## INSTRUCTIONS FOR ASSEMBLY LUBRIGUN

- 1) Assemble drum cover to pump.
  - a) Remove cover nut from top of pump. Lift air motor cover from pump.
  - b) Remove the four screws holding the cover-bottom to the pump outlet body.
  - c) Hold pump with pump outlet body resting securely on the inner surface of the cover-bottom. Insert end of pumptube through hole in drum cover. Line up holes in drum cover, cover-bottom and pump outlet body. Replace the four screws and tighten securely.
- 2) Assemble the four casters into the base.
- 3) Place fresh drum of lubricant centrally on base between the four base clamps.
  - a) Base clamps are adjustable to fit the various diameter drums.
  - b) Clamp drum rigidly to the base by tightening the clamp studs securely.
- 4) Push insert through wiper body with small cone of wiper body facing up. Place insert retainer over insert and align the holes on the insert and insert retainer. Secure assembly with four self-tapping screws.
- 5) Remove drum top and insert follower into drum (insert side up) against the surface of the lubricant.
- 6) Insert pump into lubricant drum.
  - a) Guide end of pumptube into the follower insert.
  - b) Lower pumptube into lubricant drum until drum cover rests on top bead of drum. Insert the three adjusting screws into the drum cover and tighten securely to hold the pump to the drum.
- 7) Assemble the lubricant hose to the pump outlet body. Connections must be leakproof.
- 8) Replace airmotor cover.
  - a) Place cover over airmotor and position over cover-bottom.
  - b) Replace cover nut on pump stud to hold airmotor cover securely in place.
  - c) Assemble nipple and adapter through hole in side of airmotor cover and into airmotor. Connection must be leakproof.
- 9) Assemble air coupler to an air hose of sufficient length so that lubrigun can be moved to cover the entire lubrication area with hose attached. When air coupler is attached to air coupler nipple, lubrigun is ready for operation. To release air coupler, draw back on the coupler sleeve.

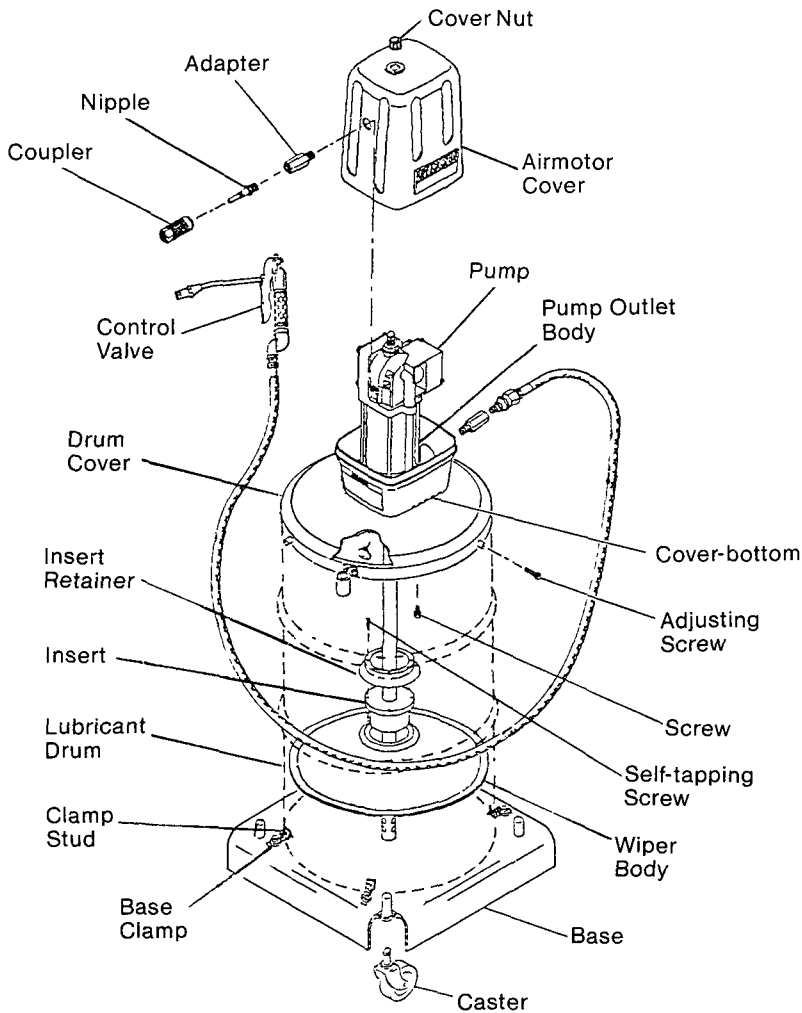

## SERVICE PARTS

Part	Qty.	Description
740	1	Control valve
815	1	Air coupler
11123	4	Set screw
11348	2	Adapter
11478	1	Cover nut
11659	1	Nipple
45761	1	Control valve hanger
45880	1	Truck plate
46007	1	Drum cover
48238	4	Washer
50016	4	Screw
50060	4	Screw
50113	2	Screw
50415	3	Drum cover screw
50754	2	Nut
66060	4	Caster
75084	1	High pressure hose
80895	1	Truck assembly
81387	1	Universal swivel
82050	1	Basic pump assembly
82399	1	Straight swivel
84780	1	Follower
241561	1	Airmotor cover
241567	1	Cover-bottom
360266	4	Clamp

### RETAIN THIS INFORMATION FOR FUTURE REFERENCE

When ordering replacement parts, list: Part Number, Description, Model Number, and Series Letter.

LINCOLN provides a Distributor Network that stocks equipment and replacement parts.